

REV#	COORD	CHANGE MADE	DATE	FIRST MACHINE SERIAL NUMBER EFFECTED	APPROVED BY	REQUIREMENTS	RTG
-	-	-	-	-	-	1) BREAK ALL SHARP EDGES	OPER-1

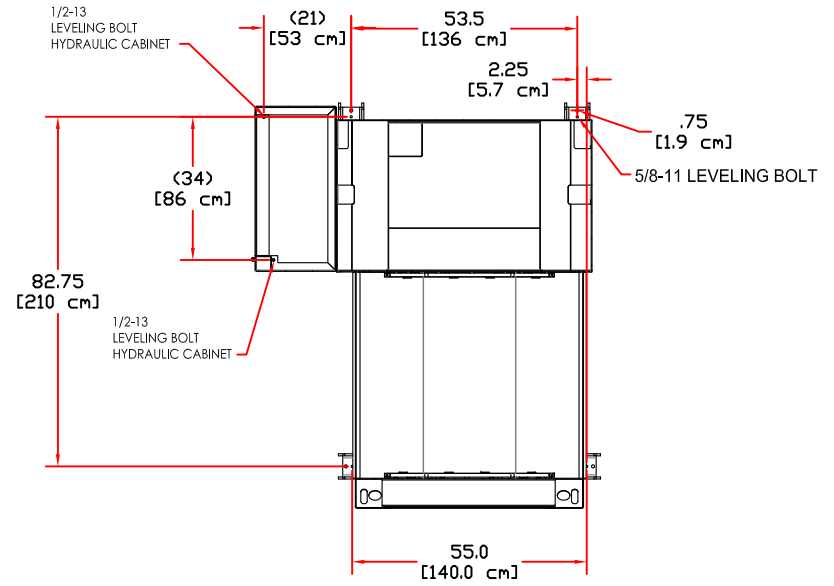

FOUNDATION PLAN

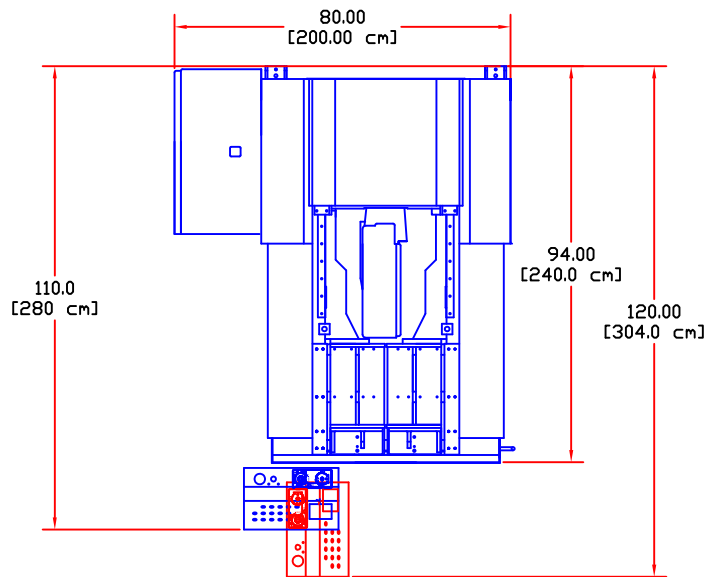
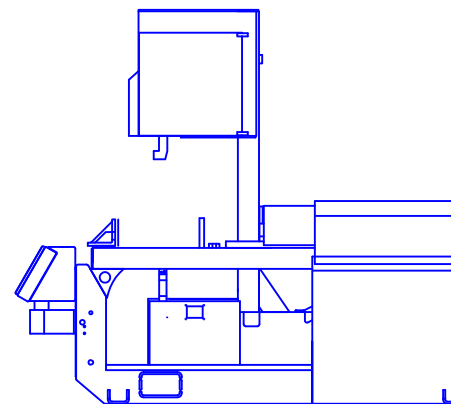
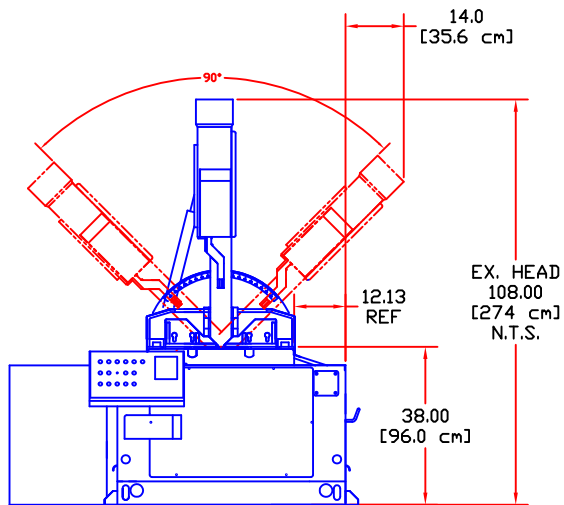

OPER-1
-
OPER-2
-
OPER-3
-5
-
OPER-4
-
OPER-5
-
OPER-6
-
OPER-7
-
OPER-8
-
OPER-9
-

TOLERANCES UNLESS OTHERWISE SPECIFIED:			QTY/MACH.	MTL.WGT.	PART WGT.	DRAWN BY	DATE	CHKD BY	DATE	HYD-MECH PUEBLO, INC.	PART NUMBER J0000000	REV A
ANGULAR:	.X	+/- 0.5 DEG	-	-	-	-	-	JACK TADUS	10/99		SHEET 1 OF 1	
DEC:	.X	+/- .015 IN	MATERIAL CODE		OVERALL MATERIAL SIZE		CUT LENGTH		PART DESCRIPTION			
DEC:	.XX	+/- .010 IN	-		-		-		V18 PRODUCTION BAND SAW MACHINE			
DEC:	.XXX	+/- .005 IN	-		-		-		-			